



Shanghai Sino Trading Co.,LTD

Email:shanghaisino@163.com
y.k.p.poligraf@mail.ru

TEL: +7(920) 764-45-72
+86 152 9675 5980



product list

产品目录

■ 印刷器材耗材Printing supplies	1~11
■ 辅助设备Auxiliary equipment	8
■ 研磨抛光Grinding and polishing	11
■ 耐高温热屏蔽产品High temperature heat shielding products	11~13
■ 气动元件Pneumatic Components	13~15
■ 工业自动控制器材Industrial automatic control equipment	15~19
■ 静电控制Static electricity control	19~22
■ 粘度控制Viscosity control	22~23
■ 流体设备Fluid equipment	24~25
■ 张力控制Tension control	25~27
■ 测试仪器Testing instruments	28~33
■ 色彩检测Color detection	33~39
■ 套色控制系统color-register control system	40~43

刮墨刀 Doctor Blade

印刷器材耗材 Printing supplies

刮墨刀广泛应用于凹印、柔印、涂布上光及装饰材料印刷等行业。

Doctor blade is widely used in gravure, flexo printing, glazing and decorative coating materials, printing and other industries.

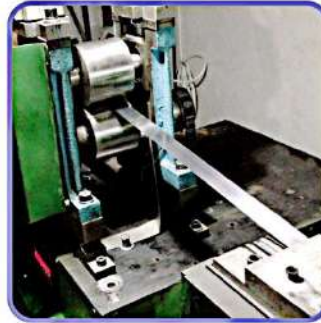

AARON Doctor Blade

品牌Brand: AARON

型号Model: 200/300/500/600#

常用规格Common size:

W30/40/50/60*T0.15/0.2mm*L100m

材质Material: 碳钢carbon steel、不锈钢stainless steel

特殊规格可订制!

Special specifications can be customized!

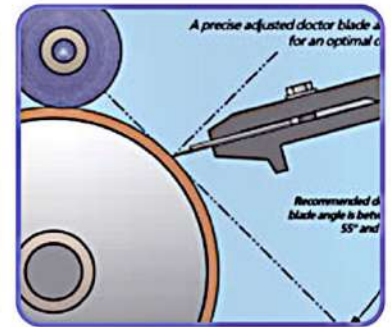

Am Doctor Blade

品牌Brand: AM

型号: 中速 / 中高速/高速/长寿命

Model: middle speed/middle-high speed/high speed/long-life

常用规格Common size: W10/22/25/30/35/40/50/60*T0.15/0.2mm*L100m

材质Material: 碳钢carbon steel



AKE Doctor Blade

品牌Brand: AKE

名称Name: 刀片Blade

常用规格Common size:

W10*T0.065mm*L300m/ W10*T0.076mm*L250m/W10*T0.102mm*L200m/W10*T0.152mm*L125m

名称Name: 背刀Back blade

常用规格Common size:

W8*T0.152mm*L125m/ W8.5*T0.152mm*L125m

材质Material: 碳钢carbon steel、不锈钢stainless steel

名称Name: 组合式刀夹combined doctor blade holder

规格可订制! Specifications can be customized!

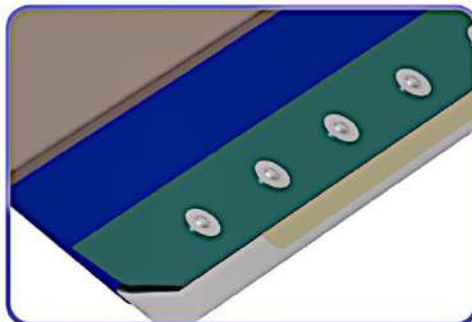

MDC Doctor Blade

品牌Brand: MDC
 型号Model:标准型standard type/长寿命long-life/Bluestar
 常用规格Common size:
 W10/20/25/30/35/40/50/60*T0.15/0.2mm*L100m
 材质Material: 碳钢carbon steel、不锈钢stainless steel
 Other models e-mail



SWEDCUT Doctor Blade

品牌Brand: SWEDCUT
 型号Model:350/550/650/750#
 常用规格Common size:
 W10/20/30/35/40/50/60*T0.15/0.2mm*L100m
 材质Material: 碳钢carbon steel、不锈钢stainless steel
 Other models e-mail



AARON Back Blade

名称Name: 背刀back blade
 常用规格Common size:
 T0.15*W8/30/40/50/60mm
 T0.20*W30/40/50/60mm
 T0.30*W25/50/60mm
 T0.40*W35mm
 T0.50*W38/45/53mm
 材质Material: 碳钢carbon steel

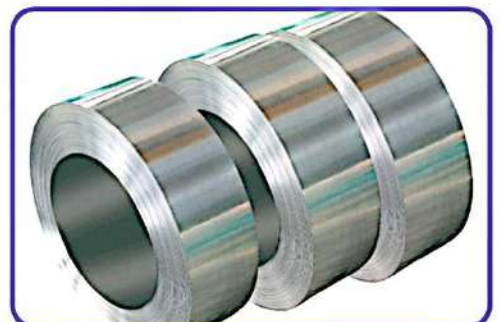

Doctor Blade

印刷器材耗材 Printing supplies



AD Doctor blade super



CBG Doctor blade



+ECO GRAPH Doctor blade

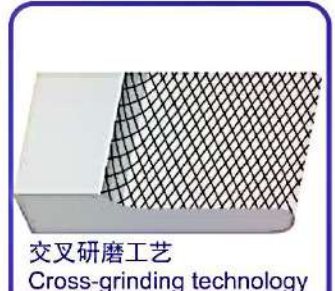

交叉研磨工艺
Cross-grinding technology

+ECO GRAPH Doctor blade



DECER Doctor blade

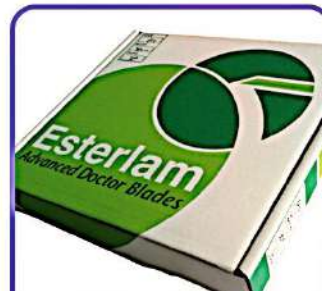

Esterlam Advanced Doctor blade



Esterlam Advanced Doctor blade



TKM MEYER Doctor blade



uddeholmstrip Doctor blade

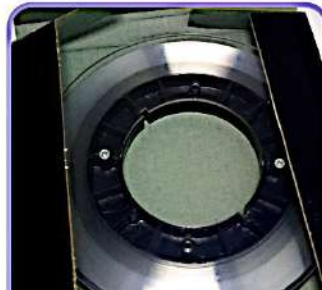

uddeholmstrip Doctor blade



SCHNEIDER Doctor blade



SND Doctor blade

Other knives



MOZART分切刀片



Schroder分切刀片



裁刀



平圆刀片

磁性搅墨棒Magnetic ink mixing roller

1. 光面型Smooth finish type: $\Phi 42/55\text{mm}^*L$
2. 缠绳型Rope wrapped type: $\Phi 12/18/22/25/32/42/55\text{mm}^*L$
3. 一体化型Integration type: $\Phi 42/55\text{mm}^*L$
4. 一体化塑胶型Integration plastic type: $\Phi 42\text{mm}^*L$
5. 一体化万能型Integration all purpose type: $\Phi 40/50\text{mm}^*L$
6. 双向八线搅墨棒Two-way eight line magnetic ink roller: $\Phi 42\text{mm}^*L$
7. 双向八线隔离型
Two-way eight line magnetic ink roller with insulation rings : $\Phi 42\text{mm}^*L$
8. 双向八线塑胶型
Two-way eight line magnetic ink roller plastic type : $\Phi 42\text{mm}^*L$
9. 递墨辊Drop ink roller : $\Phi 50\text{mm}^*L$



光面隔离型



八线



八线隔离型



缠绳型



一体黑

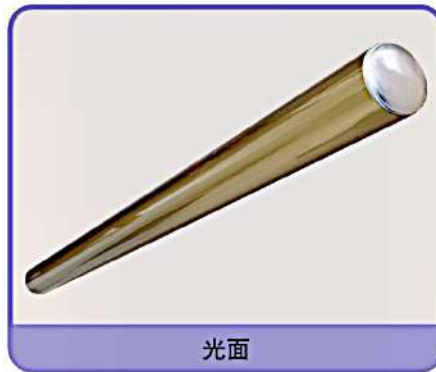

光面



多纹端盖突出型

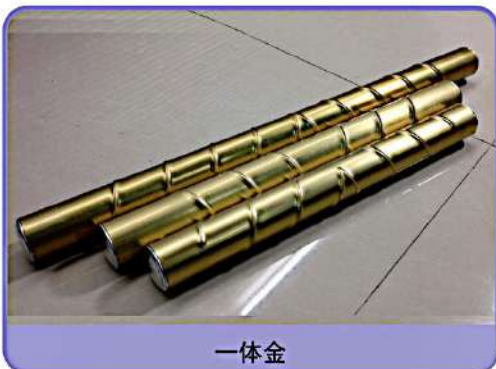

一体金



一体金

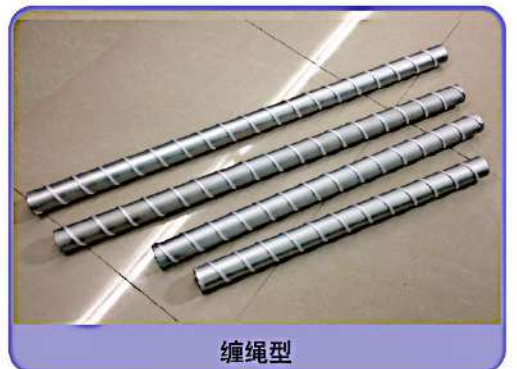

缠绳型

Ink Mixing Roller

印刷器材耗材 Printing supplies



一体隔离型



一体隔离型



一体密纹型



一体塑胶型



一体型



塑胶棒



一体万能型



递墨辊

Strong magnetic bar

强磁棒 Strong magnetic bar

强磁棒内置超强磁铁，应用于油墨生产或印刷行业。可减轻特殊行业中被金属杂质干扰生产质量的情况。

Strong magnetic rod built-in super magnet, used in ink production or printing industry.

It can reduce the situation that metal impurities affect production quality in special industries.

sizes: $\Phi 25\text{mm} * L$

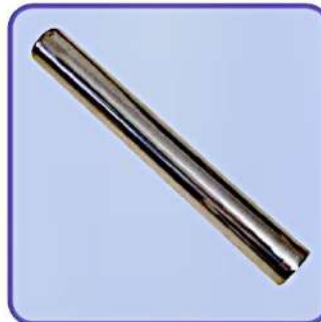

Ink filter

RECYL 磁性墨水过滤器 RECYL ink filter

原理：油墨过滤器安装在油墨墨路中，并允许保留各种杂质或粉尘，这是由于其过滤盒具有很强的磁性。

油墨类型：水性油墨，溶剂及UV油墨。

优点：油墨过滤器延长了印刷的寿命，保护版辊，提高了印刷质量。

Principle: The ink filter is settled in the inking circuit and allows to retain all kinds of impurities or dusts thanks to its filtering cartridge and its very powerful magnet.

Ink type:

Water-based inks, solvent & UV inks.

Advantage:

The ink filter prolongs the lifetime of printing peripherals, protects your anilox and improves clearly the print quality.

Dimensions: H182* $\Phi 146\text{mm}$



Ceramix anilox roller

陶瓷网纹辊广泛应用于瓦楞纸箱印刷、柔性版印刷、涂布及胶印行业等。

Ceramix anilox roller widely used in corrugated box printing, flexographic printing, coating and offset printing industries.

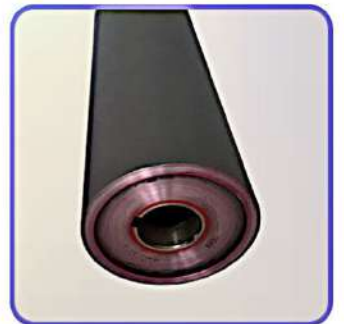
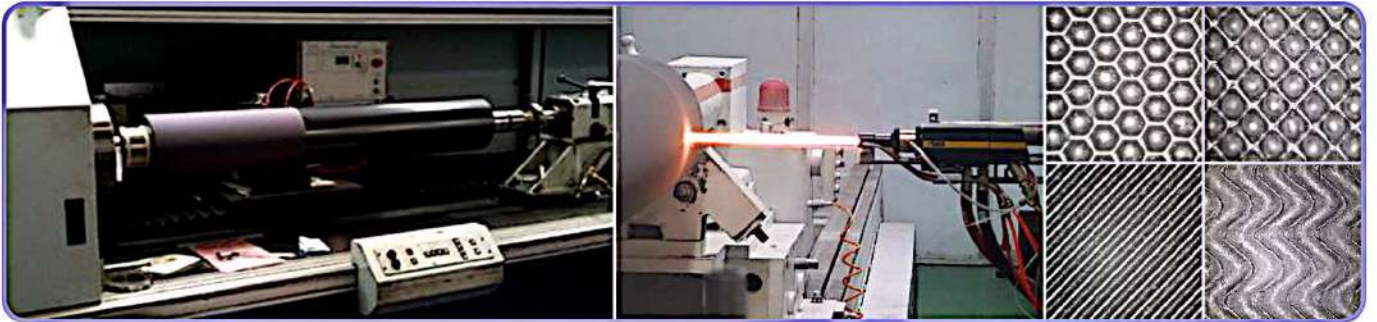

Embossing roller

压纹辊Embossing roller

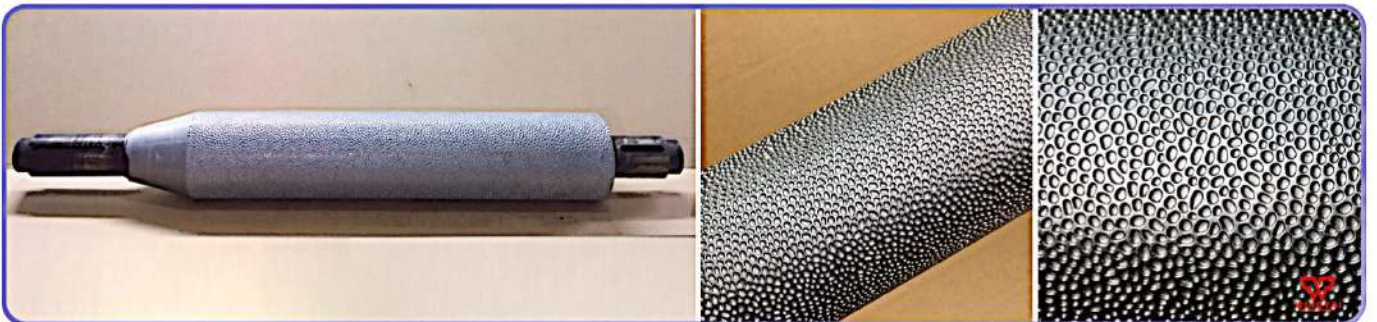

Rubber roller

橡胶辊用于印刷机械，作为压印、调墨、传墨之用的胶辊。

Rubber roller used for printing machinery, as a roller for imprinting, ink transfer, and ink transfer.



轴承Bearings



齿轮gear



弹簧spring

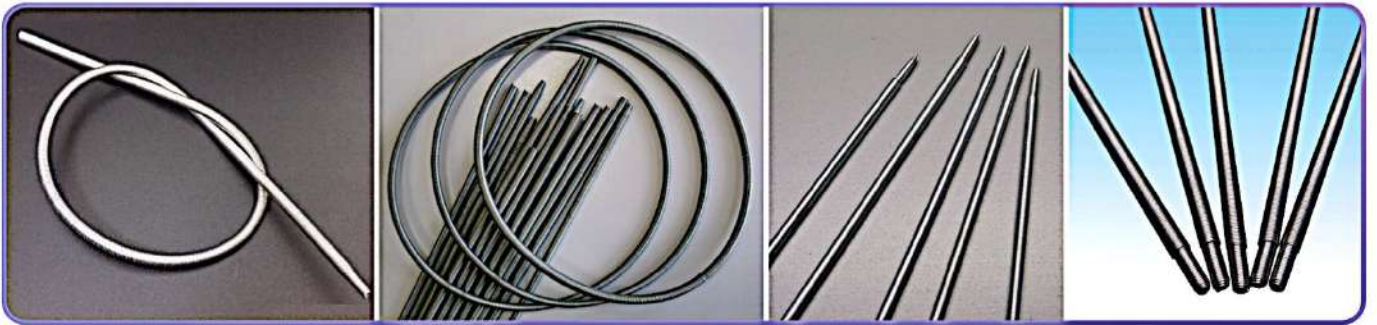

刀模Knife mold



刀模Knife mold



刀模Knife mold



封刀Sealing knife



热切刀Hot knife

软包装在线激光切割机

Flexible Packaging Online Laser Cutting Machine



行业应用：将激光设备装置在分切机上，应用激光技术在软包装袋上切割易撕线。其加工方法是利用激光器产生的光束，通过聚焦在设计好的易撕线处均匀的切割出一条细线，该线破坏了复合膜的外层包装，保留内层包装，既不破坏包装功能，又使撕裂时可以规则地沿易撕线撕开包装袋口。

Applications: It cuts the easy tear lines installing slitting machine via laser cutting technology. The processing method is to take advantage of the light beam which produced by the laser device by focusing designed easy tear line, then cut a thin line, the line will damage the outer layer of the composite film packaging, inner packaging reservations, not undermine the package function. So you can easily tear along the tear line of the packaging bag rulely .

技术参数Technical Parameters :

工作方式：画实线、虚线

Working Way: Draw Full Lines 、 Dotted Lines

最快切割速度：实线最高速度为：120m/min 虚线最高速度为：100 m/min

Fastest Cutting Speed: Full Lines Fastest Speed :120m/min ; Full Lines Fastest Speed: 100 m/min .

工作电源Power Supply: AC220V±10% 50HZ

总功率Gross Power: ≤ 1000W

Solvent recovery machine

溶剂回收机工作原理:蒸馏原理

加热棒加热热媒油,热媒油传热到废溶剂,溶液升温,有机溶剂受热后由液态转化为汽态;汽态溶剂经冷却系统液化流出,分离出来的清洁溶剂流入回收器皿.

Solvent recovery machine working principle: distillation principle

The heating rod heats the heat medium oil, and the heat medium oil transfers heat to the waste solution. The temperature of the solution is increased. The organic solvent is heated and then converted from a liquid state to a vapor state. The vaporized solvent flows out through the cooling system, and the separated cleaning solvent flows into the recovery vessel.



cleaning machine

网纹辊超声波清洗机Anilox ultrasonic cleaning machine

原理:将电信号转换成机械振动而传入到清洗液中,当超声波在液体传播时,清洗液分子受到压缩及膨胀,产生机械力,从而将工件清洗干净.

Principle: The electrical signal is converted into mechanical vibration and transmitted to the cleaning liquid. When the ultrasonic wave propagates in the liquid, the cleaning fluid molecules are compressed and expanded, generating mechanical force, thereby cleaning the workpiece.



表面张力测试笔 Surface Tension Test Pens



SHERMAN



SHERMAN

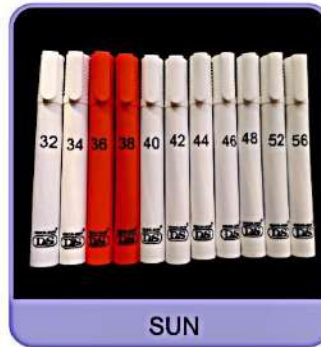

SUN

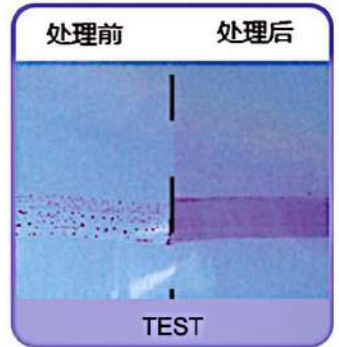

TEST



ARCOTEST



ARCOTEST



ACCU



ACCU

Cleaning agent

网纹辊清洗剂 Anilox roller cleaning agent



RECYL CLEAN 2000



RECYL CLEAN PLUS



RECYL COBRA



RECYL COBRA SET



RECYL W200



RECYL QUICK WASH BOOSTER



RECYL QUICK WASH UV



RECYL MAGIC CLICHE

Cleaning

印刷器材耗材 Printing supplies



SP-751/700ml



SP-751/20kg



SP-752/1kg



SP-752/2kg



9800+



洗版膏 Washing paste



喷粉 printing spray powder



玻璃纤维棒 Fiber glass stick

Cleaning brush



铜丝刷 copper wire brush



不锈钢丝刷 Stainless steel wire brush



尼龙刷 Nylon brush



Brush work

Consumables

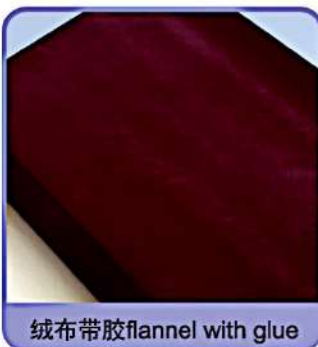

绒布带胶 flannel with glue



丝网 Wire mesh



标准擦布 Standard rubbing cloth



亮光擦拭布 Gloss wipe

Grinding and polishing

印刷器材耗材Printing supplies

网目研磨布Mesh abrasive cloth

KOYO/POLINET; 180/280/320/400/600/800/1000#; 230*280mm/1050mm*215m

日本光阳研磨布Japan Gwangyang abrasive cloth; 180/600#; 230*280mm

BELL STAR AGJ研磨砂纸Abrasive sandpaper; 80/320/400/600/1000#; 230*280mm

KOVAX日本红鹰 WATERPROOF ABRASIVE PAPER; 120~2000#; 230*280mm



Mesh abrasive cloth



Mesh abrasive cloth



Mesh abrasive cloth



Abrasive sandpaper



Abrasive sandpaper



Abrasive sandpaper

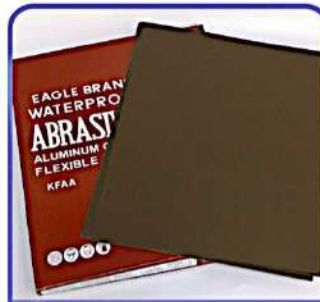

Abrasive sandpaper



Abrasive sandpaper

Insulation products

耐高温热屏蔽产品High temperature heat shielding products



硅胶板silicone board

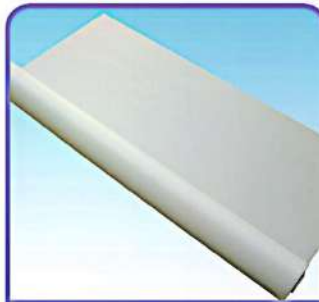

Teflon cloth



NITTO Teflon cloth



Teflon cloth



Smooth surface Teflon cloth



Teflon cloth with release film

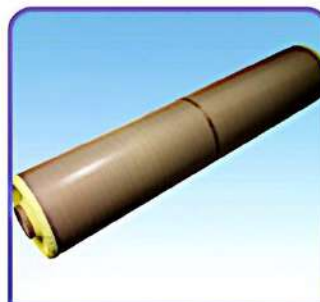

Teflon cloth with release film



Teflon cloth with release film

Adhesive Tapes

耐高温热屏蔽产品 High temperature heat shielding products

铁氟龙树脂产品 P.T.F.E Resin Product

耐热胶带 Heat Resistant Tape 无铅 Lead Free 阻燃 Flame Retardant

玻璃布浸渍四氟 Glass Cloth Impregnated With P.T.F.E

Nitto No.903ul/973ul/



Adhesive Tapes

Nitto No.923s/3800A/523/443/spv-225/5608N

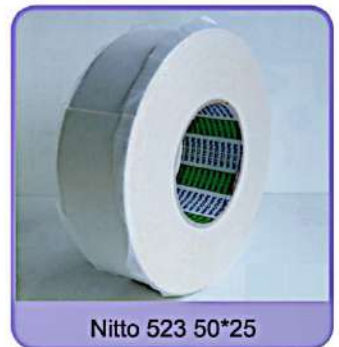

Adhesive Tapes

耐高温热屏蔽产品 High temperature heat shielding products



3M CIP36/0.13*25*10



CHUKOH ASF-110FR/0.08*13*10



TACONIC/0.13*25*10



TOFO/0.13*13*10

Pneumatic punching

气动冲孔 Pneumatic punching

气动冲孔机 Pneumatic hole punch machine

可根据客户提供样品或图纸制作

According to customer needs to provide samples or drawings

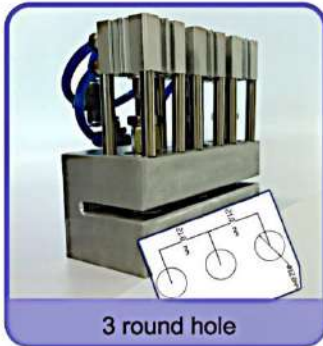

3 round hole



9 round hole

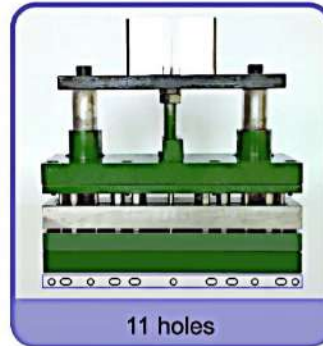

11 holes



Φ25mm round hole



70*20mm Portable hole

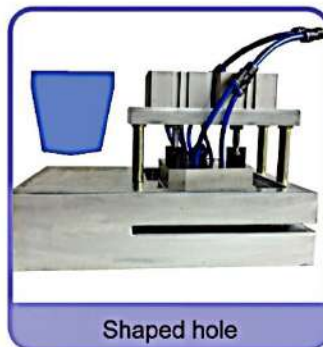

Shaped hole



30*6*9mm Aircraft hole

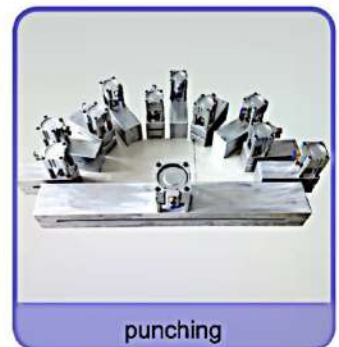

punching



Aircraft hole manual control



90*20mm Portable hole



17.7*8.84*1.6mm Round edge



Round hole + oval

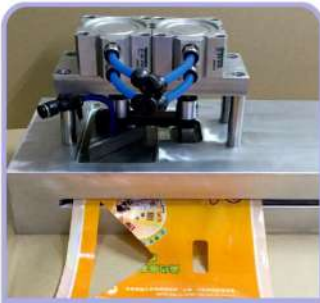

triangle+rectangle

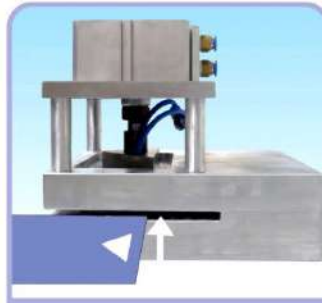

triangle

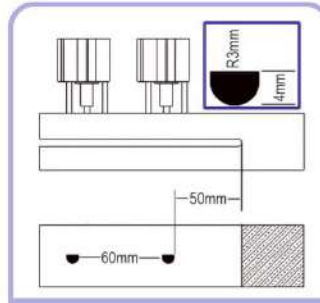

2 semicircle



80*20mm Portable hole

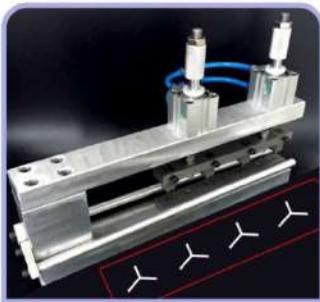

4 Breathing hole

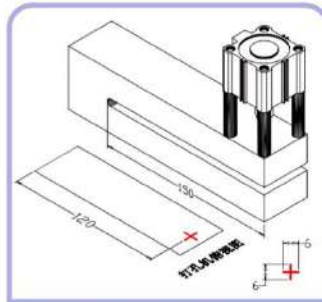

"+"6*6mm Breathing hole



4*2mm*2 Easy tear hole



Φ20mm round hole

Cylinder

气缸Cylinder

调压阀Pressure regulator



日本小金井气缸RAPS5-90



SQW气缸QCN 32-50M



金开气缸TDA20-30-S



天奥气缸TDA25*60



KORTIS低摩擦气缸
KCS 59-75-S1-P



德国费斯托FESTO气缸
E-63-78-SAP028



台湾匡信气缸
MPT-5T维修包



亚德客Airtac调压阀
SR200-08

Pressure Cylinder

气动元件Pneumatic Components

增压缸Pressure Cylinder



台湾匡信13T直压式增压缸



台湾匡信增压缸
MPT-80-150-10-5T



台湾匡信增压缸
MPT-80-150-15-5T



SENTO水平安装型增压缸
STA-A-80-150-5-5T

Electromechanical

工业自动控制器材Industrial automatic control equipment



FOTEK温度调节器
temperature controller NT-20



FOTEK温度调节器
temperature controller NT-48



FOTEK温度调节器
temperature controller NT-72E



FOTEK温度调节器
temperature controller TC72-DD-R3



FOTEK温度调节器
temperature controller TC-96-AA



FOTEK传感器
wheel encoder WE-M1



FOTEK传感器
wheel encoder WE-M2



FOTEK传感器
wheel encoder WE-M3



FOTEK传感器
photo sensor MR-60X



FOTEK传感器
photo sensor QL-05N



FOTEK传感器
photo sensor MR-60N



FOTEK接近开关
Proximity switch PS-05N

计数器Counter 计时器Timer 计米器Meter counter
 变频器Inverter 模块Modules 固态继电器Solid state module
 可控硅模块Solid state module



FOTEK计数器
counter MC-341



FOTEK计数器
counter MC-361



FOTEK计数器
counter HC-51P



FOTEK计数器
counter HC-52P



FOTEK计数器
counter H5C-4D

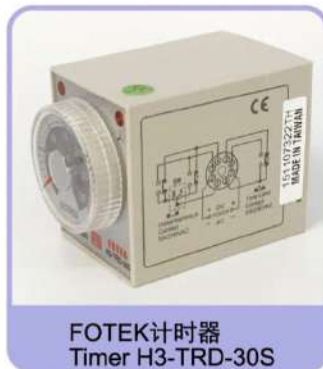

FOTEK计时器
Timer H3-TRD-30S



韩国奥托尼克斯计数器
AUTONICS counter FS4A



计数器
wheel encoder Z96-F



FOTEK可控硅模块
Solid state module ACR-80LA



西门康SEMICON晶体管(可控硅模)
Solid state module SKM75GB12V1



亚泰计米器
Meter counter JMX72



台达Delta变频器
Inverter VFD007B23A



三菱模块Mitsubishi
Modules A171SHCPUN



FOTEK固态继电器
Solid state module SSR-40 AA



FOTEK固态继电器
Solid state module SSR-40 DA



FOTEK固态继电器
Solid state module SSR-40 DD

接近开关 Proximity switch 行程开关 Limit switch 光电开关 Photoelectric switch
 电流表配套互感器 Ammeter Support Transformer 编码器 Encoder 石墨碳刷 Graphite carbon brush
 热电偶 Thermocouple 电磁阀 Solenoid valve



台湾ROKO接近开关
Proximity switch SN04-N



台湾Tend行程开关
Limit switch TZ-8107



Waytop光电开关
Photoelectric switch CDD-40N



电流表配套互感器
Ammeter Support Transformer



多摩川编码器
TAMAGAWA Encoder TS2650N11E78



日本安川编码器
Encoder UTSIH-B17CK



石墨碳刷
Graphite carbon brush



石墨碳刷
Graphite carbon brush



热电偶
Thermocouple K 5m



热电偶
Thermocouple K 5m



热电偶
Thermocouple M6 2m



热电偶 Thermocouple
WRNX-10C E 4m



台湾金器MINDMAN电磁阀
Solenoid valve MVSC-220-4E1 DC24V



台湾金器MINDMAN电磁阀
Solenoid valve MVSC-260-4E1 DC24V

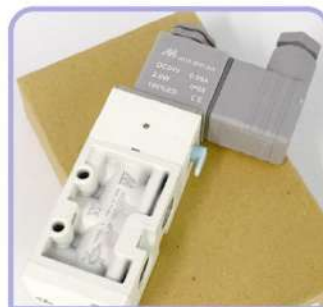

台湾金器MINDMAN电磁阀
Solenoid valve MVSC-260-4E1 DC24V



台湾金器MINDMAN电磁阀
Solenoid valve MVSC-220-4E2 DC24V

吹膜机宽度检测仪 Film blowing machine width detector

位置控制仪 Position controller 微电脑纠偏控制器 Microcomputer controller 超声波发生器 Ultrasound generator

步进驱动器 Motor Driver 风扇 Fan 电机 Motor

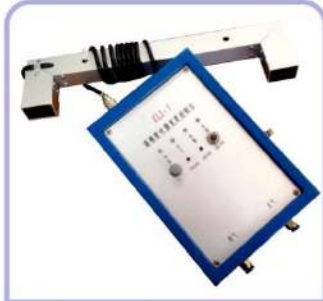

吹膜机宽度检测仪
Film blowing machine width detector ZLJ-6



吹膜机宽度检测仪
Film blowing machine width detector BF-III



吹膜机宽度检测仪
Film blowing machine width detector BF-III

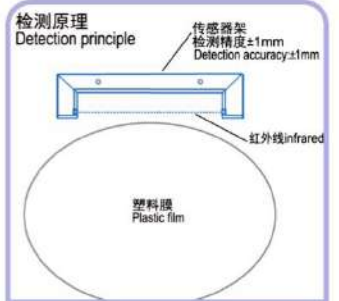

吹膜机宽度检测仪
Film blowing machine width detector



吹膜机宽度检测仪
Film blowing machine width detector



位置控制仪
Position controller DC2001A



微电脑纠偏控制器
Microcomputer controller EPC-D12



超声波发生器
Ultrasound generator 2500W



步进驱动器
Motor Driver HB-B3CE



马达驱动器
Motor Driver HB-B3HL



三相混合式电机驱动器
motor driver WD3DV07



台湾福佑风扇
Fan UF6030CBA23HL



JSCC电机
Motor 90YB120GY22



JSCC电机
Motor 90YF60GV22



JSCC电机
Motor 90YT90GV22



JSCC减速箱
Gearbox 90GK7.5HK

Electromechanical

工业自动化控制器材 Industrial automatic control equipment

减速机 Reducer 步进电机 Stepping motor 伺服电机 servo motor



日本住友减速机
Reducer CNHM 1-6090



SOYO步进电机直轴
Stepping motor 130BYG350B



SOYO步进电机带卷轮
Stepping motor 130BYG350C



安川伺服电机
servo motor SGMGH-09ACA61

仪表 Meter



电子数显秒表
Electronic stopwatch TA210



机械秒表
Mechanical stopwatch



温湿度计指针式
hygrometer TH885



数显温湿度计
hygrometer HTC-1

Static electricity control



离子发生器
Ion generator 4.6KV



消除静电装置
Elimination of electrostatic devices

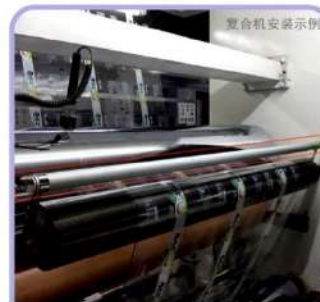

消除静电装置
Elimination of electrostatic devices

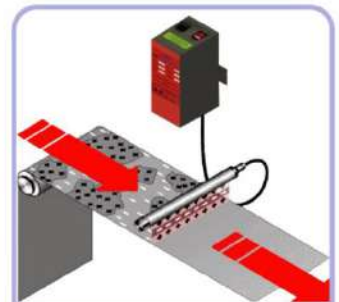

工作示意图
Working diagram



离子发生器
Ion generator 7KV



消除静电装置 15KV
Elimination of electrostatic devices



离子风枪 Ionic air gun
离子发生器 Ion generator 4.6KV



离子风枪 Ionic air gun
离子发生器 Ion generator 4.6KV

荣泰公司致力于引进国际最先进的静电控制产品与技术，为客户提供最优秀的专业静电解决方案。

WINGTAI Committed to the introduction of the world's most advanced electrostatic control products and technologies, to provide customers with the best professional electrostatic solutions.



台式离子风机
Desktop ion fan SL-001



离子风机
Desktop ion fan SL-002



SIMCO静电场测量仪FMX004
Electrostatic field measuring instrument



SIMCO静电场测量仪FMX004
Electrostatic field measuring instrument



英国FRASER 715
Electrostatic field measuring instrument



静电带W50mm
Static electricity cloth



101碳刷 "h"
Carbon fiber brush



碳纤维刷
Carbon fiber brush



除静电带刷
Carbon fiber brush 406-7

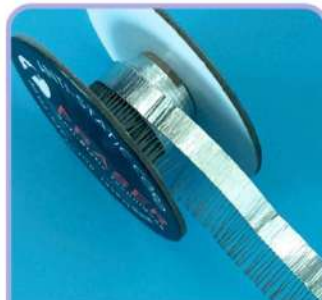

除静电带刷
Carbon fiber brush 409-11



碳纤维刷
Carbon fiber brush



碳纤维刷
Carbon fiber brush



碳纤维刷
Carbon fiber brush



TAKK除静电绳
Anti-static flexicord 5683



TAKK除静电绳
Anti-static cord 5681



FRASER除静电绳
Anti-static cord 850

荣泰公司致力于引进国际最先进的静电控制产品与技术，为客户提供最优秀的专业静电解决方案。

WINGTAI Committed to the introduction of the world's most advanced electrostatic control products and technologies, to provide customers with the best professional electrostatic solutions.



除静电绳
Anti-static cord Φ 6mm



防静电棉签
Anti-static cotton swab



FRASER 101碳刷 "h"
Carbon fiber brush

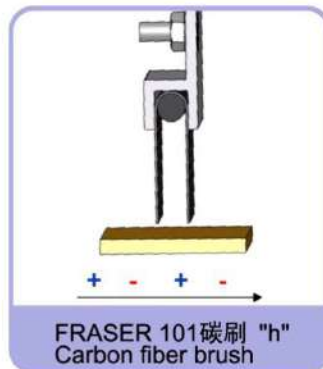

FRASER 101碳刷 "h"
Carbon fiber brush



FRASER 除静电铜丝
801 Anti-static tinsel

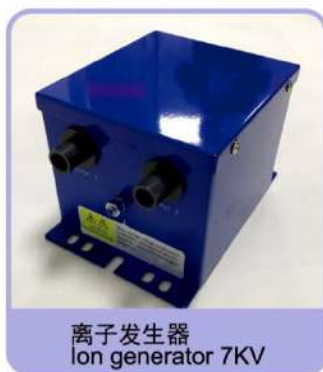

离子发生器
Ion generator 7KV



消除静电装置
Elimination of electrostatic devices



静电除尘机650mm
Electrostatic precipitator



FRASER 3850可控静电消除器
Controlled static eliminator



FRASER 5100 高效型离子风刀
High-efficiency ion wind knife



FRASER 7080/7081静电发生棒
Static electricity generation stick

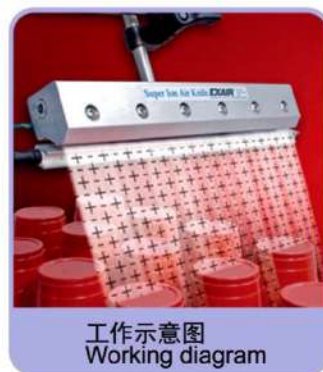

工作示意图
Working diagram



FRASER EX715防爆型
Electrostatic field measuring instrument

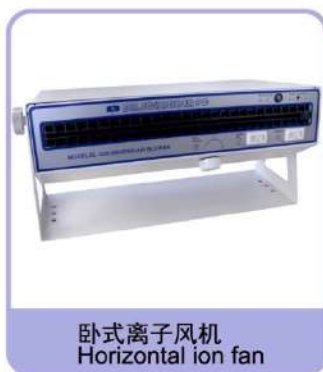

卧式离子风机
Horizontal ion fan



工作示意图
Working diagram



离子风鼓
Ionic wind drum

Static electricity control

静电控制 Static electricity control



离子风嘴
Ion tuypere



离子风蛇
Ionic Wind Snake



离子风蛇
Ionic Wind Snake



离子风蛇
Ionic Wind Snake

Viscosity control

粘度控制 Viscosity control

在印刷行业生产过程中由于油墨和胶水的粘度会随着溶剂的挥发粘度会发生变化, 所以需要粘度控制器和粘度测量工具进行测量, 以及自动控制粘度, 以保证生产过程中液体粘度的一致性。

In the printing industry, the viscosity of the ink and glue will change with the volatility of the solvent. Therefore, the viscosity controller and the viscosity measurement tool are required to measure and the viscosity is automatically controlled to ensure the consistency of the liquid viscosity in the production process.



粘度控制器10/15/20#
Viscosity controller



粘度控制器10/15/20#
Viscosity controller



武士粘度控制器V10/15/20#
Viscosity controller



武士粘度控制器V10/15/20#
Viscosity controller



粘度控制器DS-885
Viscosity controller



浸杯粘度杯
AARON Viscosity Cups



浸杯粘度杯
TOYO Viscosity Cups



浸杯粘度杯
NIPPO Viscosity Cups



荷兰 浸杯粘度杯
TQC Viscosity Cups



岩田杯
ANEST IWATA NK-2



涂4杯便携式
Viscosity Cup 4



涂4杯支架式
Viscosity Cup 4

Viscosity control

粘度控制Viscosity control

粘度量杯, 粘度计测量粘度值

Viscosity measuring cup, viscometer to measure viscosity



DIN杯 DIN Cup
DIN杯便携式DIN Cup(hand-held)



福特杯
Ford Cup



福特杯便携式
Ford Cup(hand-held)



ISO杯
ISO Flow Cup



粘度计
NDJ-1 Viscometer



数显旋转式粘度计
SNB-3 Viscometer



斯托默粘度计186#
Stormer Viscometer186#



标准油
Standard oil

Stirring/dispersing

电动搅拌机用于实验室统计测量用途; 气动搅拌机用于生产车间, 防爆, 安全! Electric mixers are used for laboratory statistical measurement purposes; pneumatic mixers are used in production workshops, explosion-proof, and safe!



400W电动搅拌机
Electric Dispenser



740# 电动搅拌机
Electric Dispenser



气动搅拌机
Pneumatic mixer 304L645



台式气动搅拌机
Pneumatic mixer EA230



台式气动搅拌机
Pneumatic mixer EA500



台式气动搅拌机
Pneumatic mixer 800



推车式气动搅拌机
Pneumatic mixer 800U



推车式气动搅拌机
Pneumatic mixer 1000U

气动隔膜泵 Pneumatic diaphragm pump

是一种流体输送设备, 采用压缩空气做为动力源。

Is a fluid delivery device. Use compressed air as a power source.



5#泵
5#Pump 10L/min 3/8"



5#泵+
5#Pump 10L/min 3/8"



10#泵
10#Pump 15L/min 3/8"



10#泵+
10#Pump 15L/min 3/8"



10#泵C
10#Pump 15L/min 3/8"



10#泵C
10#Pump 15L/min 3/8"



15#泵
15#Pump 35L/min 1/2"



15#泵
15#Pump 35L/min 1/2"



15#泵P
15#Pump 35L/min 1/2"



20#泵
20#Pump 54L/min 3/4"



25#泵
25#Pump 160L/min 1"



25#泵P
25#Pump 160L/min 1"



25#泵S
25#Pump 160L/min 1"



40#泵
40#Pump 379L/min 1.5"



40#泵P
40#Pump 379L/min 1.5"



50#泵D
50#Pump 568L/min 2"



40#泵D
40#Pump 379L/min 1.5"



50#泵
50#Pump 568L/min 2"



50#泵P
50#Pump 568L/min 2"



80#泵A
80#Pump 1135L/min 3"



PU管
PU tube



台湾志观泵
Pump AM6



齿轮油泵
Oil pump CB-B6



油泵泵头
Oil pump ROP-13AVB

MITSUBISHI ELECTRIC

三菱电机MITSUBISHI ELECTRIC

三菱电机—电磁离合器, 制动器为代表的执行机, 到控制这些设备的张力控制器, 提供用户设备性能提升的综合解决方案。
MITSUBISHI ELECTRIC—Electromagnetic clutches and brakes are the representative actuators, and the tension controllers that control these devices provide comprehensive solutions for improving the performance of the user equipment.



离合器
clutch ZKB-0.6AN



离合器
clutch ZA-0.6A1



离合器
clutch ZA-2.5A1



离合器
clutch ZKB-1.2BN



离合器
clutch ZKB-5BN



离合器
clutch ZKB-20BN



离合器
clutch ZA-10A1



制动器
Brake ZA-5Y1

三菱电机—电磁离合器、制动器为代表的执行机，到控制这些设备的张力控制器，提供用户设备性能提升的综合解决方案。
 MITSUBISHI ELECTRIC—Electromagnetic clutches and brakes are the representative actuators, and the tension controllers that control these devices provide comprehensive solutions for improving the performance of the user equipment.

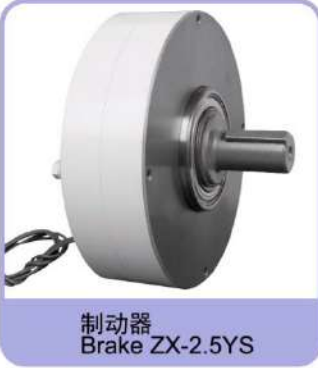

制动器
Brake ZX-2.5YS



制动器
Brake ZX-0.6YN-24



制动器
Brake ZKG-50YN



制动器
Brake ZKB-0.3YN



制动器
Brake ZKB-2.5XN



制动器
Brake ZKB-5HBN-C



制动器
Brake ZKB-5XN



制动器
Brake ZKB-5XN



制动器
Brake ZKB-10XN



制动器
Brake ZKG-5YN



制动器
Brake ZKG-10YN



制动器
Brake ZX-0.3YN-24

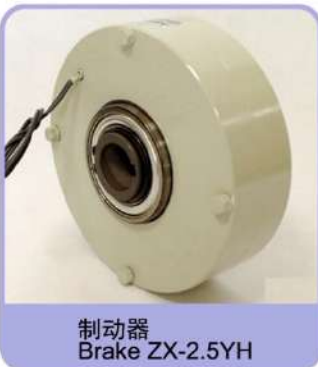

制动器
Brake ZX-2.5YH



张力检测器
Detector LX-015TD



张力检测器
Detector LX-030TD



张力检测器
Detector LX-050TD



功率放大器
Power amplifier LE-50PAU



功率放大器
Power amplifier LM-10TA



张力表
Tension Meter LM-10PD



张力表
Tension Meter LM-10PD



全自动张力控制器
Tension Controller LE-30CTA



半自动张力控制器
Tension Controller LD-30FTA



手动功率调节器
Power Regulator LD-40PSU



全自动张力控制器
Tension Controller LE-40MTA-E

Domestic motor

国产电机Domestic motor

光电纠偏控制器是一种跟踪工作材料的边缘或印刷线条进行高准确度的差动和摆动可选择纠偏控制器, 光电纠偏控制系统由纠偏控制器, 光电眼, 电机伺服机构成。

Photoelectric correction controller is a kind of tracking edge of the working material or printed lines for high accuracy of the differential and swing selectable error correction controller. Photoelectric correction control system consists of correction controller, photoelectric eye, servo motor composition.



制动器
Brake FZ-25B-2



制动器
Brake FZ-100A-1



空压蝶式制动器
Brake DBG-205



台湾仟岱离合器
Clutch MG-KEB-5



纠偏控制系统
Correction control system EPC-D12



伺服电机
servo motor



张力控制器
Tension Controller EPC-261



超声波光电眼
Ultrasonic photoeye

荣泰是中国领先的软包装检测仪器和检测方案供应商。公司为全球100多个国家和地区的机构提供了完善的实验室建设方案和检测仪器。WINGTAI--China's leading provider of flexible packaging testing equipment and testing solutions. The company provides comprehensive laboratory construction programs and testing instruments for organizations in more than 100 countries and regions.



GBB-A型热封仪
GBB-A One-point Heat Seal Tester



GBB-F型五点热封仪
GBB-F Five-point Heat Seal Tester



GBB-H型热封仪
GBB-H Electronic Heat Sealing



N500气体透过率测定仪
N500 Gas Permeability Analyzer



W301水汽透过率测定仪
W301 Water Vapor Permeability Analyzer



W301水汽透过率测定仪
W301 Water Vapor Permeability Analyzer



Gx-B2型圆盘剥离试验机
Gx-B2 Disk Stripping Tester

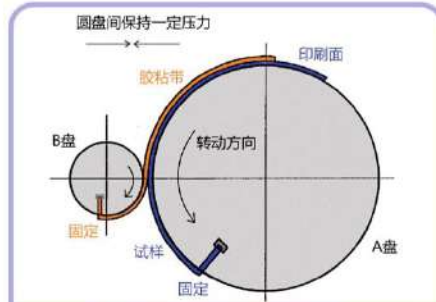

Gx-B2型圆盘剥离试验机
Gx-B2 Disk Stripping Tester



Gx-Y2型胶粘带压滚机
Gx-Y2 Adhesive Tape Rolling Pressing Machine



GC-9801气象色谱仪
GC-9801 Gas Chromatograph



氢空氮一体机
NHA-300 Gas Generator



ZM-100反压高温蒸煮消毒锅
ZM-100 Inverted Pressure Sterilized Boiler

荣泰是中国领先的软包装检测仪器和检测方案供应商。公司为全球100多个国家和地区的机构提供了完善的实验室建设方案和检测仪器。WINGTAI--China's leading provider of flexible packaging testing equipment and testing solutions. The company provides comprehensive laboratory construction programs and testing instruments for organizations in more than 100 countries and regions.



GBL-L电子拉力机
GBL-L Electronic Tensile Tester



GHH万能材料试验机
GHH Electronic Tensile Tester



XLW(B)智能电子实验拉力机
XLW(B) Electronic Tensile Tester



GM-1摩擦系数测定仪
GM-1 Coefficient of Friction Tester



GM-4摩擦系数测定仪
GM-4 Coefficient of Friction Tester



GB-M密封实验仪
GB-M Leakage Tester



GBD-B摆锤冲击测定仪
GBD-B Pendulum Impact Tester



纸张挺度测定仪
RH-T50 Paper Stiffness Tester



易高F106-5拉开法附着力测定仪
Elcometer F106-5 Adhesion Tester



Schroder圆盘取样器
GSM-CUTTER 100CM2



圆柱弯曲试验仪 564
Cylindrical Mandrel Bend Tester



圆锥弯曲试验仪 566
Cone bending tester

荣泰是中国领先的软包装检测仪器和检测方案供应商。公司为全球100多个国家和地区的机构提供了完善的实验室建设方案和检测仪器。WINGTAI--China's leading provider of flexible packaging testing equipment and testing solutions. The company provides comprehensive laboratory construction programs and testing instruments for organizations in more than 100 countries and regions.



UV光固化机 CB300
UV light curing machine



UV光固化机 RX200-1
UV light curing machine



凹版打样机 CB100-EX
Gravure proofer

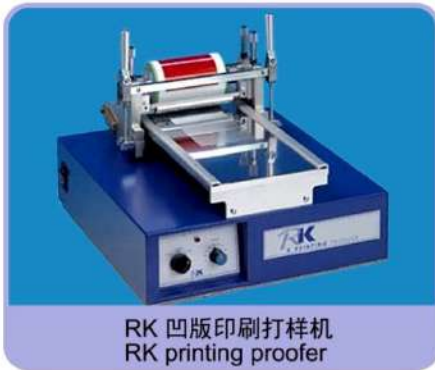

RK 凹版印刷打样机
RK printing proofer



凹印油墨印刷打样机 622/1
Gravure ink printing proofer



柔印油墨印刷打样机 622/2
Flexo printing ink proofer



自动匀墨式展色机 CB225A
Ink proofer CB225A



手动展色轮
Manual Ink Proofer



OSP涂膜棒L250mm
OSP Coating stick



AARON 刮色棒
AARON Coating stick



AARON 刮色棒
AARON Coating stick



RDS 线棒
RDS Coating stick



RK 线棒
RK Coating stick

荣泰是中国领先的软包装检测仪器和检测方案供应商。公司为全球100多个国家和地区的机构提供了完善的实验室建设方案和检测仪器。WINGTAI—China's leading provider of flexible packaging testing equipment and testing solutions. The company provides comprehensive laboratory construction programs and testing instruments for organizations in more than 100 countries and regions.

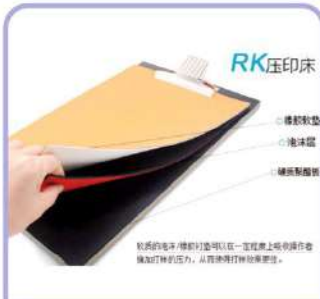

RK 压印床
RK Coating stick Soleplate



可调式制备器 209/1
Adjustable Applicator



可调式制备器 209/3
Adjustable Applicator



可调式制备器 KTQ-180
Adjustable Applicator



单面制备器
One-sided Applicator



双面制备器
Two-sided Applicator



四面制备器
Four-sided Applicator



立方体制备器
Cubic Applicator



框式制备器
Applicator frame-type



刮板细度计/单槽
Fineness of Grind Gauge/Single Groove



刮板细度计/双槽
Fineness of Grind Gauge/Double Groove



刮板细度计
Fineness of Grind Gauge



漆膜划格器/单面
Cross Cut Tester/Single side



漆膜划格器/六面
Cross Cut Tester/Six sides



流平仪
Flow leveler Instrument



流挂仪
Sagging tester



湿膜厚度滚轮
Wet Film Applicator



涂层测厚仪 QNIX4500
Coating Thickness Gauges



德国Fischer涂层测厚仪Dualscope MPO
Coating Thickness Gauges



涂层测厚仪 WH81/82
Coating Thickness Gauges



涂层测厚仪 540
Coating Thickness Gauges



涂层测厚仪 543系列
Coating Thickness Gauges



PHS-3B数字式酸度计
Digital pH meter



袖珍数显笔式酸度计
Pocket-sized PH Meter



MN-R型反射率仪
0/45 Reflectance Meter



反射率测定仪 581
Reflectance Meter 45/0



比重杯(铝) 100ml
Specific gravity cup(aluminum)



比重杯(不锈钢) 100/50ml
Specific gravity cup(stainless steel)



外径千分尺0~25/0.01mm
Outside diameter micrometer



L1H数显千分尺0~25/0.001mm
Outside diameter micrometer



MMT数显千分尺/单尖头
Outside diameter micrometer



XC02数显千分尺/单尖头
Outside diameter micrometer



表盘测厚仪BC02 0.01mm
Dial Thickness Gauge



表盘测厚仪0.001mm 0~1mm
Dial Thickness Gauge



表盘测厚仪G-6C 0.001mm
PEACOCK Dial Thickness Gauge



表盘测厚仪0.01mm 120mm
Dial Thickness Gauge



连续测厚规0.01mm 0~10mm
Continuous thickness gauge



连续测厚规0.01mm 0~10mm
Continuous thickness gauge



连续测厚规0.001mm 0~12.7mm
Continuous thickness gauge



数显测厚规0.001mm 120mm
Digital thickness gauge



数显测厚规0.01mm 0~12.7mm
Digital thickness gauge



数显测厚规0.001mm 0~25mm
Digital thickness gauge



数显测厚规 圆头 0.001mm
Digital thickness gauge



数显测厚规0.001mm 0~12.7mm
Digital thickness gauge

Color detection

色彩检测 Color detection



标准光源对色灯箱CAC-600
Standard light source color light box



标准光源对色灯箱CAC-1200L
Standard light source color light box



PANTONE标准光源对色灯箱P5D50840
Standard light source color light box

Color detection

色彩检测Color detection



爱色丽Judge QC光源箱
X-Rite Judge QC Light Box



标准光源看样台/桌面型
Standard light source to see sample stage



标准光源看样台 透射反射
Standard light source to see sample stage



标准光源看样台 反射 斜面
Standard light source to see sample stage



标准光源看样台CC120反射
Standard light source to see sample stage



标准光源看样台 透射 反射
Standard light source to see sample stage

reading glass

放大镜reading glass



对色灯箱灯管
GE FDF-Q500T3 4 CL D65 lamp



放大镜 三折 金属
reading glass 10*



放大镜 三折 塑料
reading glass 10*



LED放大镜 三折 塑料
LED reading glass 5*



放大镜 带光源40*
reading glass 40* With light source



放大镜 带光源100*
reading glass 100* With light source



放大镜 带光源200*
reading glass 200* With light source



放大镜 带光源300*
reading glass 300* With light source

reading glass

放大镜reading glass



放大镜 带光源
reading glass 30*



放大镜 LED
reading glass 10*



放大镜 笔式
reading glass 25*



放大镜 LED
reading glass 10*

PANTONE

PANTONE Color Card



PANTONE可撕色票
GB1307



PANTONE可撕色票
GB1505



PANTONE可撕色票
GB1507 金属色8字头



PANTONE可撕色票
GP1606N CU

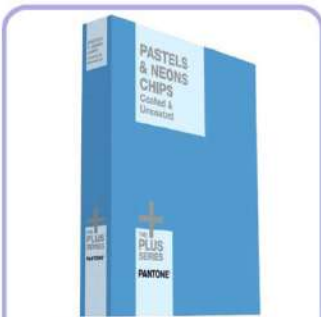

PANTONE可撕色票
GB1504 粉彩 霓虹色



PANTONE可撕色票
GP1608N



PANTONE可撕色票
GP1303XR



PANTONE可撕色票
GB1404 粉彩 霓虹色



PANTONE色卡
GG1305



PANTONE色卡
GG1507 8字头



PANTONE四色桥梁
GG6103 C



PANTONE粉彩色9字头
GG1504



PANTONE色卡
GG1505 金属色



PANTONE色卡
GG1407 金属色8字头



PANTONE四色桥梁
GG5103 C



PANTONE金属色
GP1507



PANTONE色卡
GP1605N

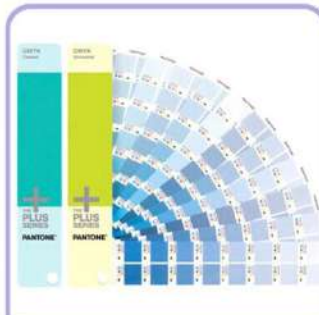

PANTONE色卡
GP5101 CU CMYK



PANTONE色彩桥梁
GP6102N CU



PANTONE色彩桥梁
GP5102 CU



PANTONE可撕色票
FHC100棉布版



PANTONE可撕色票
FHC200棉布版

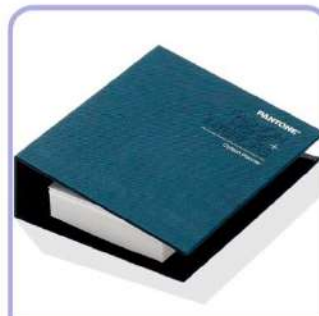

PANTONE可撕色票
FHC300棉布版



PANTONE可撕色票
FHC400棉布版



PANTONE色卡
FHIP110N



PANTONE可撕色票
FHIP200 TPG



PANTONE纺织色卡
FGP200 TPX



PANTONE可撕色票
FBP200 TPX

PANTONE

PANTONE Color Card



PANTONE色卡
GP1601N



PANTONE可撕套装
FPP120 TPX



PANTONE肤色色卡
STG201



PANTONE工作室套装
GPG304N 9本



PANTONE5册装
FFC123 TCX 棉布版



PANTONE TN尼龙色卡
FFN100



PANTONE塑胶不透明
PBQ100



PANTONE GoeGuide
GSPS005

COLOR CARD

Color Card



RAL色卡
K1



RAL色卡
K5



RAL色卡
K7



RAL色卡
D2



RAL色卡
E3



NCS色卡 高光泽
G-1



NCS色卡 半光泽
A-6



NCS色卡
NC-1

COLOR CARD

Color Card



AATCC灰卡
沾色用灰卡A03



JAMES标准沾色灰卡
ISO 105 A03



变色用灰卡
ISO 105 A02



JPMA-J工业涂料标准色卡
2017版

Color measuring

颜色测量Color measuring



孟赛尔色棋Farnsworth Munsell
100 M80000



PANTONE色彩检测仪
RM200-PT01



便携式成像分光色差仪
X-Rite RM200QC



爱色丽图版测量仪
X-Rite iCPlate2



爱色丽分光光度仪
X-Rite Ci60



CI60/CI62/CI64

爱色丽分光光度仪
X-Rite Ci62



爱色丽分光光度仪
X-Rite Ci64



爱色丽多角度分光光度仪
X-Rite MA94



色差仪
WF28 8mm



色差仪
WF30 8mm



色差仪
WF32 8mm



三角度光泽度仪
WG68



色差仪
FRU10



色差仪
WR18



单角度光泽度仪
FRU60



色差仪
HP-2136



色差仪
NR110



色差仪
NR200



色差仪
NH300/310



爱色丽台式分光光度仪
X-Rite Ci4200



色差仪
CS-10



色差仪
CS-210



色差仪
CS-260



三角光泽度计
CS-380



分光测色仪
CS-660



台式分光测色仪
CS-800



透射分光测色仪
CS-810



透射反射分光测色仪
CS-820



套色光纤DT-860
Light Guides Optical Fiber



套色光纤KPLG-300/DT-950
Light Guides Optical Fiber



套色光纤(NIRECO)MR-5000EX
Light Guides Optical Fiber



套色光纤(NIRECO)MR-5000EX
Light Guides Optical Fiber



PHILIPS卤素灯Halogen Lamp
JCR 12V-20WA20H/3



KLS卤素灯Halogen Lamp
JCR 12V-20WA20H/3



EYE PROJECTOR HALOGEN LAMP
投影卤素灯 JCR 12V30W 20H/G1



Kesai LAMP
KS2000III



Kesai 键盘keyboard
KS2000III



Kesai 光电头连接线
Photoelectric cable



Kesai 套色系统主机
2000E



Kesai 套色控制单元
Control unit ST-2000E



Kesai 套色控制单元
Control unit ST-2000E+



光电头Photoelectric eyes
Kesai KSC-008



光电头Photoelectric eyes
Kesai KSC-008



编码器
Encoder



光电头Photoelectric eyes
JULONG ZDB-2BW



光电头Photoelectric eyes
JULONG ZDB-2BW



光电开关Photoelectric switch
JULONG NT6-RG22-2



光电开关Photoelectric switch
JULONG Z3N-TB22



光电开关Photoelectric switch
JULONG Z3S-TW22



光电开关Photoelectric switch
JULONG Z3N-TB22



光电开关Photoelectric switch
JULONG Z3N-TB22-2



光电开关Photoelectric switch
KETAI Z3J-DS50E3



光电开关Photoelectric switch
KETAI KS-WG22



光电开关Photoelectric switch
KETAI KT-RG22



光电开关Photoelectric switch
WEILONG NT-WG23



光电开关Photoelectric switch
WELON WS-C2G-S



光电开关Photoelectric switch
SICK KT5W-2N1116



光电开关Photoelectric switch
SICK NT6-N112



光电开关Photoelectric switch
SICK WL11G-2B2531



光电开关Photoelectric switch
SICK KT5W-2P1116



Photoelectric distance sensor
SICK光电测距传感器DT50-P1113



光电开关Photoelectric switch
SICK KT6W-2N5116



传感器sensor
SICK WTB4-3P1361



光电开关Photoelectric switch
富台KONTEC KS-C2G



光电开关Photoelectric switch
富台KONTEC KS-C2W



频闪仪Stroboscope
HS-851



频闪仪Stroboscope
HS-852



频闪仪Stroboscope
DT-2010C



频闪灯泡 加强型
Stroboscope bulb



频闪灯泡
Stroboscope bulb



频闪仪Stroboscope
RT STROBE 5000LED



频闪仪Stroboscope
HS-853 LED



频闪仪Stroboscope
DT-05/07B



频闪仪Stroboscope
DT-05/07B



频闪仪Stroboscope
HS-853



频闪仪Stroboscope
HS-853



频闪仪Stroboscope DT-03



频闪仪Stroboscope DT-02分体式

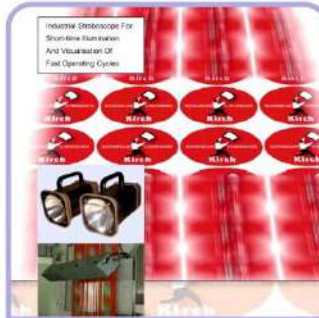

频闪仪Stroboscope 工作图像



频闪仪Stroboscope UV LED充电 DT326U



频闪仪Stroboscope LED DT325E



频闪仪Stroboscope LED DT328E



频闪仪Stroboscope LED PT-L01A



频闪仪Stroboscope LED PT-L01A



频闪仪Stroboscope PT-L200A LED



频闪仪Stroboscope PT-L02B LED



频闪仪Stroboscope PT-L02B LED



频闪仪Stroboscope PN-01D



多功能频闪仪Stroboscope SHIMPO DT-311N



印刷频闪仪Stroboscope SHIMPO DT-311P



纺织频闪仪Stroboscope SHIMPO DT-311J



频闪仪Stroboscope SHIMPO DT-311N/P



Shanghai Sino Trading Co.,LTD



Email: shanghaisino@163.com
y.k.p.poligraf@mail.ru

TEL: +7(920) 764-45-72
+86 152 9675 5980

www.sinno888.com

Address: Room J7041, Building 1, No.
2222, Huancheng Road, Juyuan New
District, Jiading District, Shanghai